

仕様 SPECIFICATIONS			
制出精度 INDEXING ACCURACY	20 sec/Rev	許容積載質量 ALLOWABLE MASS OF WORK	横 250 kg 立 125 kg
再現精度 REPEATABILITY	4 sec/Rev	許容積載ワーク径 ALLOWABLE WORK DIA.	φ250 mm
テーブル最高回転速度 MAXIMUM ROTATION SPEED	モータ 33.3 min ⁻¹ [モータ 3000 min ⁻¹]	総減速比 TOTAL REDUCTION RATIO	1/90
クランプトルク CLAMPING TORQUE	モータ 600N・m [圧力 0.5MPa]	製品質量 MASS OF ROTARY TABLE	88 kg
許容最大空圧力 MAXIMUM PNEUMATIC PRESS	0.7 MPa	駆動モーメント慣性 MASS MOMENT OF INERTIA (REDUCED TO MOTOR SHAFT)	0.00024kg・m ²

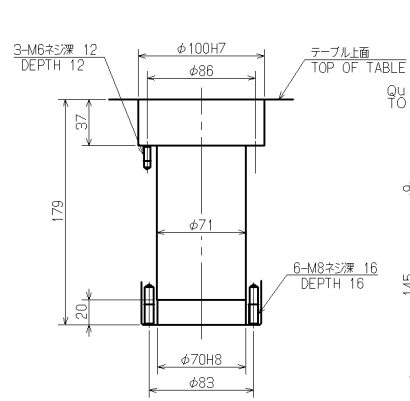

スピンドル穴
SPINDLE THRU-HOLE

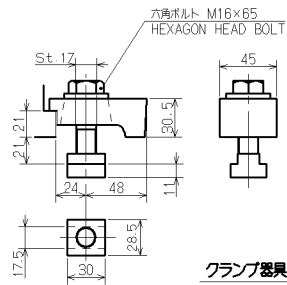
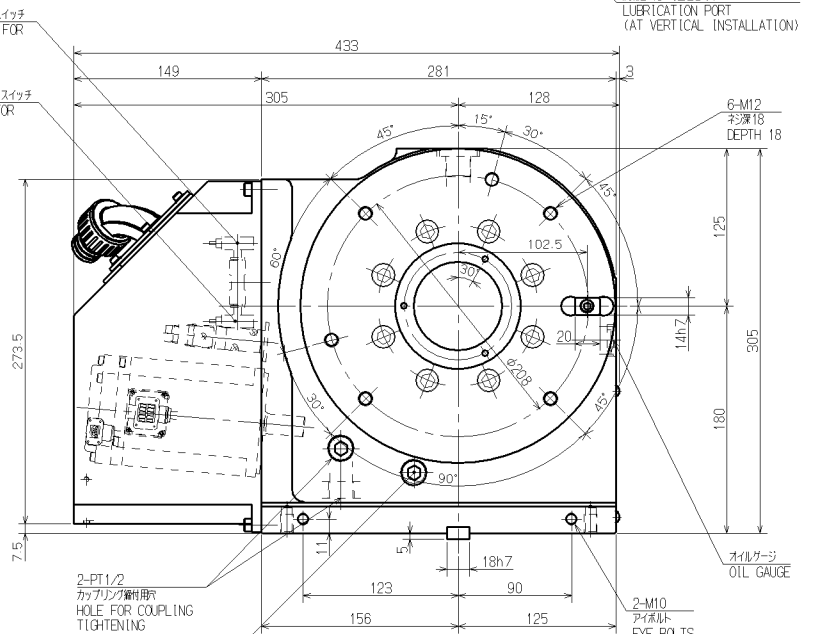
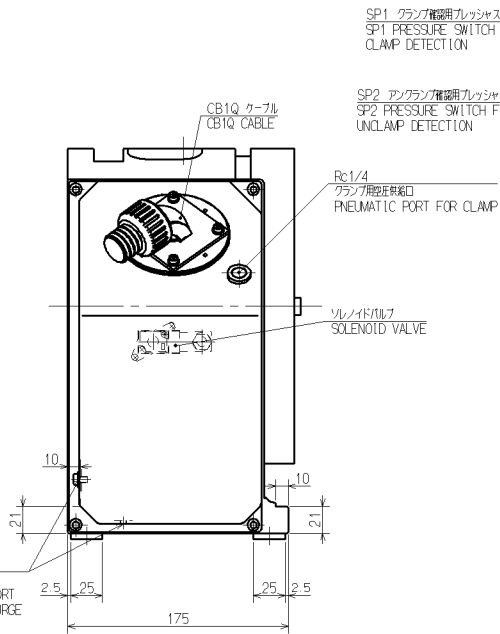
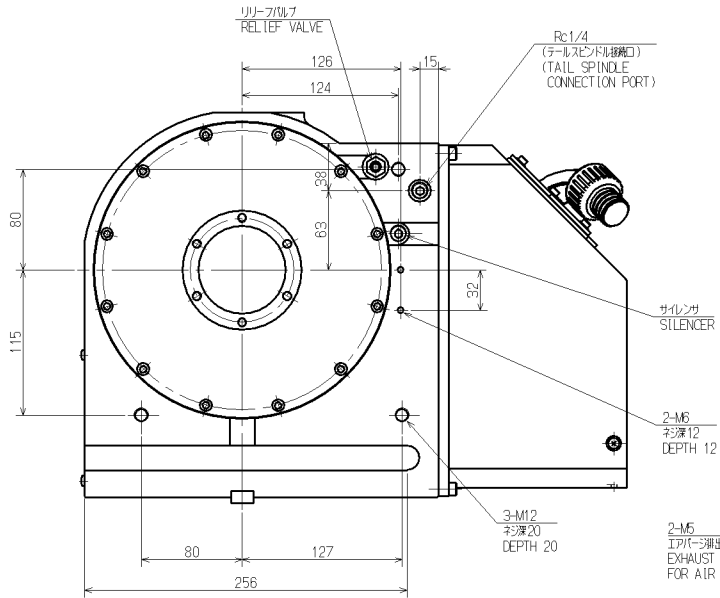
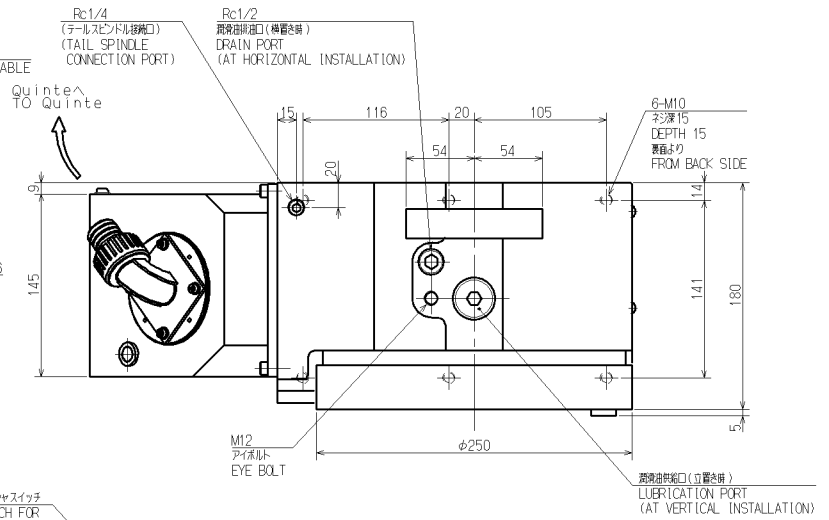

クランプ器具 付属品 4組
CLAMPING PARTS ACCESSORY 4 PAIR

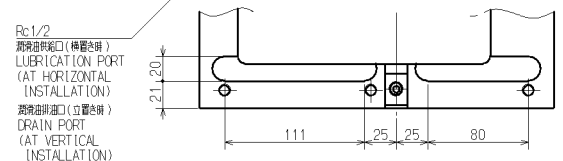
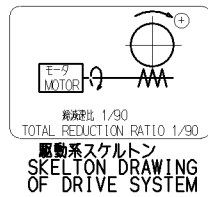

CAREER			SCALE	TYPE	MR250LAV00	WEIGHT	kg
MANAGER	CHIEF	DRAWN BY	1:3	NAME	NCテーブル NC ROTARY TABLE		
			3RD ANGLE	MR250LAV00 ガイケイ OUTSIDE VIEW			
KITAGAWA IRON WORKS CO.,LTD.			DATE	DRW NO.	61E 26 9999 0		